

CONFIGURADOR

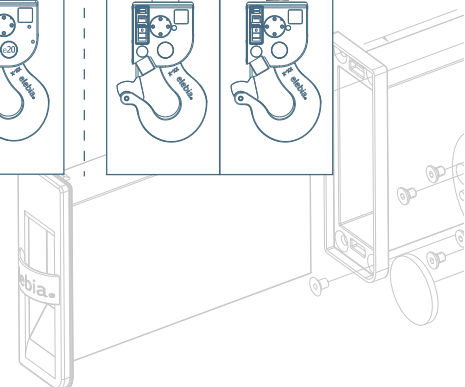

Accede a nuestro configurador online en www.elebia.com/gancho-grua/configurador

| MODELO | evo2 | | | | | evo5 | | | |
|--------|---------------------|-------------------|-------------------|----------------------------------|----------------------------------|----------------------|------------------|------------------|-----------------|
| | 2,500 kg / 5,511 lb | | | | | 5,000 kg / 11,023 lb | | | |
| | -- | Ω | P2 | ML3.15 | ML5.4 | -- | B10 | B20 | L5 |
| | | REF.: OPCIÓN UC08 | REF.: OPCIÓN UMP8 | REF.: OPCIÓN UC08 + OPCIÓN UMS16 | REF.: OPCIÓN UC08 + OPCIÓN UMS18 | | REF.: OPCIÓN B10 | REF.: OPCIÓN B20 | REF.: OPCIÓN L5 |
| | | | | | | | | | |

| evo10c | | | evo10 | | | evo20 | | evo25 | |
|-----------------------|------------------|------------------|-----------------------|------------------|------------------|-----------------------|------------------|-----------------------|------------------|
| 10,000 kg / 22,046 lb | | | 10,000 kg / 22,046 lb | | | 20,000 kg / 44,092 lb | | 25,000 kg / 55,115 lb | |
| -- | B20 | L10 | -- | B20 | L10 | -- | L20 | -- | L25 |
| | REF.: OPCIÓN B20 | REF.: OPCIÓN L10 | | REF.: OPCIÓN B20 | REF.: OPCIÓN L10 | | REF.: OPCIÓN L20 | | REF.: OPCIÓN L25 |
| | | | | | | | | | |





SISTEMA MAGNÉTICO

| | | |
|--|--|---|
| | IMÁN CON SENSOR |  |
| | POWER MAGNET  |  |







| | | |
|--|---|---|
| | POWER MAGNET & PESTILLO RÍGIDO DE SEGURIDAD  |  |
| | SIN IMÁN |  |



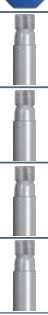

CÉLULA DE CARGA

| | | |
|--|--------------|---|
| | evo5 - evo25 |  |
|--|--------------|---|





| | | |
|--|------|---|
| | evo2 |  |
|--|------|---|



ANILLAS

| | | | |
|--|-----|---|---|
| | B10 |  |  |
| | B20 |  |  |
| | L5 |  |  |
| | L10 |  | |
| | L20 |  | |
| | L25 |  | |



| | | |
|--|--------|---|
| | Ω |  |
| | P2 |  |
| | ML3.15 |  |
| | ML5.4 |  |

ENTORNOS ESPECIALES

| | | |
|--|---|--|
| | PROTECTOR TÉRMICO  |  |
| | DNV  |  |









| | | |
|--|--|--|
| | ATEX / IECEx  |  |
| | MARINO |  |

CONTROLES REMOTO

| | | |
|--|-------|---|
| | eMAX |  |
| | eMINI |  |

| | | |
|--|-----------------|---|
| | INSTALABLE 24 V |  |
| | INSTALABLE 48 V | |

BATERÍAS / CARGADORES

| | | |
|--------------------------|--|---|
| | BATERÍA evo5 - evo25  |  |
| | CARGADOR 220V evo5 - evo25  |  |
| <input type="checkbox"/> | Cable EU | <input type="checkbox"/> |
| <input type="checkbox"/> | Cable UK | <input type="checkbox"/> |
| <input type="checkbox"/> | Cable USA | <input type="checkbox"/> |
| | CARGADOR 24V evo5 - evo25  |  |
| | CARGADOR MÚLTIPLE evo5 - evo25  |  |

| | | |
|--------------------------|--|---|
| | BATERÍA evo2  |  |
| | CARGADOR 220V evo2  |  |
| <input type="checkbox"/> | Cable EU | <input type="checkbox"/> |
| <input type="checkbox"/> | Cable UK | <input type="checkbox"/> |
| <input type="checkbox"/> | Cable USA | <input type="checkbox"/> |
| | CARGADOR MÚLTIPLE evo2  |  |

ACCESORIOS

| | | |
|--------------------------|--|---|
| | BUMPER evo5 - evo20  |  |
| | PROTECTOR TÉRMICO evo5 - evo25  |  |
| | SWIVEL LOCK evo5 - evo25  |  |
| | CAJA MALETÍN evo5 - evo20  |  |
| <input type="checkbox"/> | evo5 | <input type="checkbox"/> |
| <input type="checkbox"/> | evo10-evo20 | <input type="checkbox"/> |

| | | |
|--------------------------|---|---|
| | BUMPER evo2  |  |
| | CINTURÓN FLIP-UP |  |
| | SACOS BIG BAG |  |
| | ESLINGAS  |  |
| <input type="checkbox"/> | TUBULAR | <input type="checkbox"/> |
| <input type="checkbox"/> | DOBLE BANDA | <input type="checkbox"/> |
| <input type="checkbox"/> | BIG BAG | <input type="checkbox"/> |