

Wireless Loadshackle

Internal Antennae
Wireless Range of
1000m or 3280ft

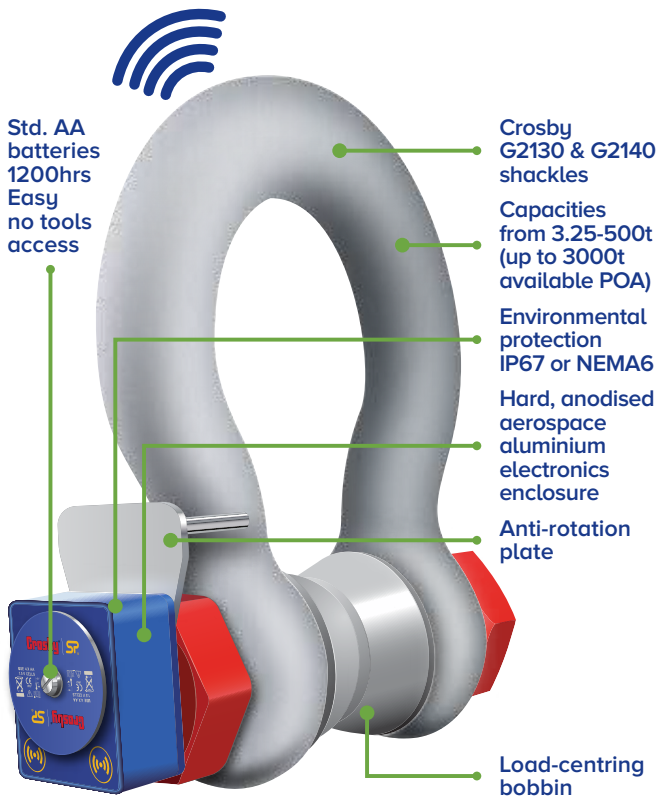

Features and benefits:

- Wireless Range of 1000m or 3280ft
- Electronics housed in hard anodised enclosure
- Environmentally sealed to IP67 or NEMA6
- Battery Life of 1200hrs from 4 x AA batteries
- Internal Antennae
- Remote On-Off from handheld display or software
- Supplied with a load-centring bobbin
- 2-year warranty
- Complies with ASME B30.26
- Design validated by F.E.A.
- ATEX Zones 0, 1 & 2 available

- Bluetooth option is available and is supplied with a free HHP App for iOS and Android
See page 21

Straightpoint's Wireless Loadshackle (WLS) provides the perfect solution to limited headroom or super heavy lift projects. Available from stock in capacities from 3.25t to 500t (up to 3000t available POA), the WLS is constructed using industry-leading shackles from Crosby.

Two versions of the WLS are available:

- Long range 2.4Ghz version, providing industry-leading wireless range of 1000m or 3280ft to SP's SW-HHP handheld or software options.
- Bluetooth output and can be connected to any smart phone running our free HHP app on iOS or Android, at ranges up to 100m or 328ft.

Each WLS is proof tested, then equipped with a hard-anodised aluminium electronics enclosure. Contained within this enclosure is an internal chassis providing IP67 or NEMA6 environmental protection, even with the battery cover plate missing.

Featuring industry leading wireless technology, the WLS can maintain an update rate of 3Hz. It can be easily configured to run at industry-leading speeds of up to 200Hz, if required for dynamic load measurement projects.

Utilising easily sourced AA alkaline batteries, the WLS features advanced circuitry, designed to protect the unit from damage associated with incorrectly installed batteries. This circuitry extends battery life, and the use of easily-sourced alkaline batteries, eliminating issues associated with rechargeable battery pack charging, failure and replacement.

The WLS may also be used with Straightpoint's SW-PTP software package, allowing the operator to perform load tests at a safe distance and generate real-time test certificates on site.

A full array of wireless accessories are also available including wireless score board, overload alarm and base station with analogue (4-20mA) or 2 relay or RS485 ASCII outputs.

Also available with hazardous
area approval. Zones 0, 1 & 2



ATEX / IECEx

Ex ia II C T4 Ga

Certification numbers:

WLS ATEX

IECEX SIR 16.0041X / Sira 16ATEX2108X

SW-HHP ATEX

IECEX SIR 15.0072X / Sira 15ATEX2196X

**Add 'ATEX' to the part number
when ordering ATEX/IECEX products.
For example: WLS3.25T-ATEX**

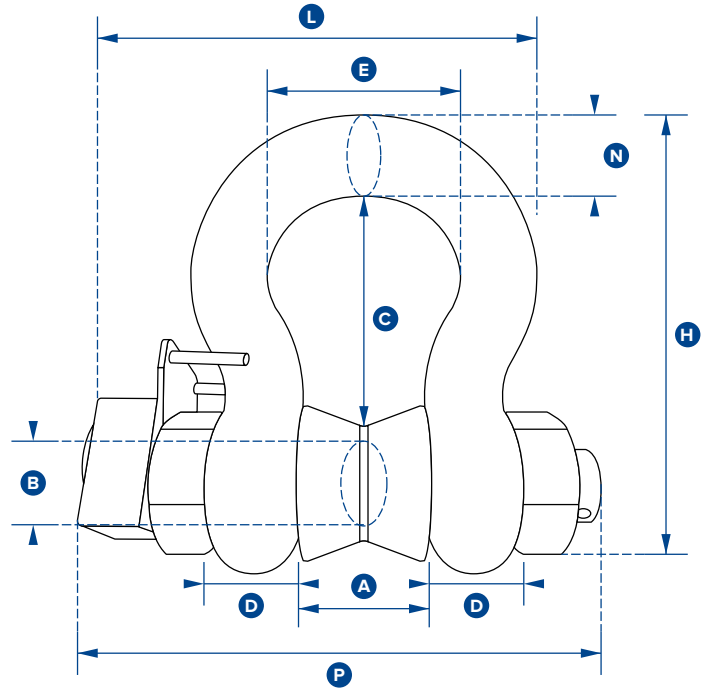

Part Numbers										
SP	WLS3.25T	WLS6.5T	WLS12T	WLS25T	WLS55T	WLS85T	WLS120T	WLS200T	WLS300T	WLS400T
Crosby	2789186	2789200	2789183	2789185	2789199	2789201	2789172	2789184	2789188	2789189
Capacity	3.25te 7150lb	6.5te 14300lb	12te 26400lb	25te 55000lb	55te 120000lbs	85te 185000lbs	120te 260000lbs	200te 440000lbs	300te 660000lbs	400te 880000lbs
Resolution	0.005te 10lb	0.005te 10lb	0.01te 20lb	0.02te 50lb	0.05te 100lb	0.05te 100lb	0.1te 200lb	0.2te 200lb	0.5te 1000lb	0.5te 1000lb
Units	tonne lb									
Weight	2.8kg 6.16lb	3.2kg 7lb	8kg 17.6lb	18kg 40lb	25kg 55lb	45kg 99lb	85kg 187lb	230kg 507lb	398kg 877lb	556kg 1226lb
Safety Factor	5:1 when used with load bobbin									
Battery Type	Load cell 4 x AA Alkaline									
Battery Life	Load cell 1200 hours continuous (500 hours if Bluetooth)									
Operating Temp	-20°C to +70°C or 4°F to 158°F									
Accuracy	±1% full scale									
Frequency	2.4 GHz									
System Range	1000 metres or 3280 feet (100 metres or 328 feet if Bluetooth)									
Data Rate	3 updates per second									
Protection	IP67 or NEMA6									
Dimension A	26.9 1.06"	36.6 1.44"	51.5 2.03"	73 2.87"	82.5 3.25"	105 4.13"	127 5.00"	184 7.24"	213 8.39"	210 8.27"
Dimension ØB	19.1 0.75"	25.4 1.00"	35.1 1.38"	51 2.01"	57 2.24"	70 2.76"	82.5 3.25"	121 4.76"	152 5.98"	178 7.01"
Dimension C	56.9 2.24"	79.7 3.14"	113 4.45"	170 6.69"	189.5 7.46"	253 9.96"	319.5 12.58"	366 14.41"	451 17.76"	542 21.34"
Dimension D	16 0.63"	22.4 0.88"	31.8 1.25"	44.5 1.75"	51 2.01"	66.5 2.62"	76 2.99"	116 4.57"	124 4.88"	165 6.50"
Dimension E	42.9 1.69"	58 2.28"	82.5 3.25"	127 5.00"	164 6.46"	184 7.24"	200 7.87"	279 10.98"	330 12.99"	330 12.99"
Dimension H	106 4.17"	148 5.83"	210 8.27"	313 12.32"	348 13.70"	453 17.83"	546 21.50"	706 27.80"	871 34.29"	1022 40.24"
Dimension L	127.1 5.00"	156.5 6.16"	196 7.72"	281 11.06"	306 12.05"	368 14.49"	408 16.06"	580 22.83"	652 25.67"	680 26.77"
Dimension N	17.5 0.69"	24.6 0.97"	35.1 1.38"	57 2.24"	61 2.40"	79 3.11"	92 3.62"	127 5.00"	154 6.06"	184 7.24"
Dimension P	143 5.63"	173 6.81"	218 8.58"	293 11.54"	317 12.48"	394 15.51"	441 17.36"	667 26.26"	722 28.43"	784 30.87"